

124-150

fill & flush valve



altecnic

124-150 fill & flush valve



Application

The Altecnic fill and flush valve is designed for use on domestic and small commercial heating systems.

The combination of two isolating valves and one 'T' port diverting ball valve are used to fill and flush the system with cleaning chemicals or water treatment.

Construction Details

Component	Material	Grade
Body	Brass	BS EN 12165 CW617N
Ball	Brass - chrome plated	BS EN 12164 CW617N
Stem	Brass	BS EN 12164 CW617N
Stem 'O' ring	EPDM	
Washer	PTFE	
Handle	Polymer	ABS
Blank cap	Brass	BS EN 12165 CW617N
Strap	PCV	

Technical Specification

Maximum Temperature:	85°C
Minimum Temperature:	2°C
Maximum Pressure:	10 bar
Compression ends complying with:	BS EN 1252-2 for use with R250 (half hard) copper tube.

Lever Positions

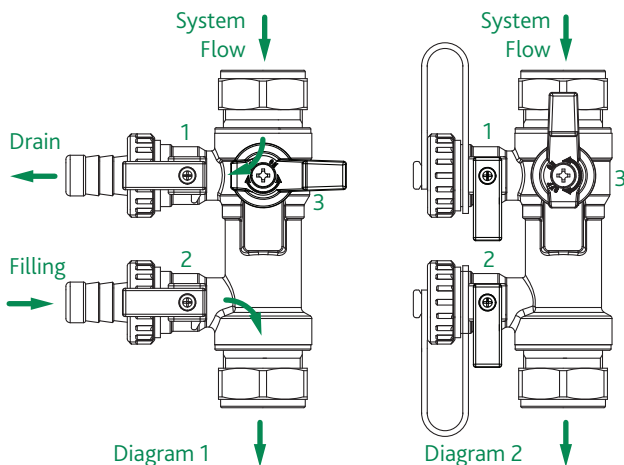

Dimensions

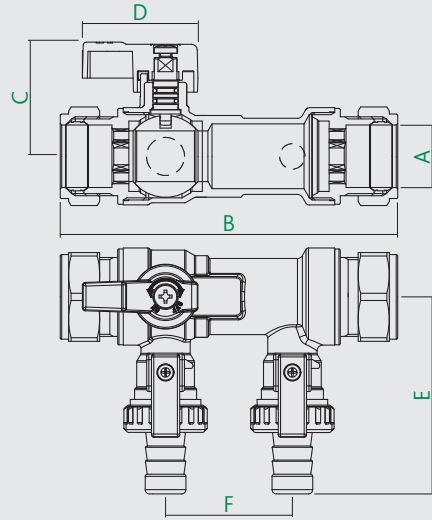

Ref No	ØA	B	C	D	E	F	kg
124-1501	22	108	40.5	41	70	45	0.59
124-1502	28	125.7	40.5	41	70	45	0.73

Fill and Flush the System

Connect the water supply to the filling connection and a hose to the drain connection - see diagram 1.

Turn valve 3 to direct the flow to drain, open valves 1 & 2 and any manual air vents.

Gradually fill the system with clean water or flushing solution until all the air has been released and the system is full, then close any manual air vents

Turn valve 3 back to system flow and operate the system - see diagram 2.

Close valves 1 & 2, pressurise the system and operate the system following the specified flushing procedure.

Final Fill and Start Up

Open valves 1 & 2 and any manual air vents then turn valve 3 to drain and allow the system to empty through the drain port - see diagram 1.

Fill the installation with water treatment / glycol mix until all the air has been released and the system is full, then close any manual air vents.

Turn valve 3 back to system flow and operate the system periodically releasing any trapped air - see diagram 2.

Close the drain valve 1 and pressurise the system.

Close the filling valve 2.

Fit the blank caps provided.

© Patents & Design Altecnic 2020

Altecnic Ltd retains all rights (including patents, designs and copyrights, trademarks and any other intellectual property rights) in relation to all information provided on or via the website, brochures or any other documents, including all texts, graphics and logos, contained on the website, in brochures or in any other documents published in the name of or on behalf of Altecnic Ltd in any form, without prior written consent of Altecnic Ltd.

Altecnic Ltd Mustang Drive, Stafford, Staffordshire ST16 1GW

T: +44 (0)1785 218200 E: sales@altecnic.co.uk

Registered in England No: 2095101

altecnic.co.uk

AL 365 09-11-20

E & O.E

© Altecnic Limited. 2020

ALTECNIC™